

## GENERAL INFORMATION

### 1.0 SCOPE OF MANUAL

This manual contains calibration, installation, and maintenance information for Moore Industries' current-to-digital display indicator (DVX). This information is presented in the following six sections:

**Section 1. General Information**, contains the physical and functional configuration of the unit. Also, includes a model number explanation.

**Section 2. Calibration Procedures**, contains information necessary for adjustment and calibration of the unit. This section also lists the test equipment and tools necessary for calibrating the DVX. A calibration setup diagram is also presented.

**Section 3. Installation and Operation**, this section contains installation information that includes recommended wiring practices and electrical connections.

**Section 4. Theory of Operation**, describes the circuit operation principles based on a simplified block diagram.

**Section 5. Maintenance and Troubleshooting**, gives step-by-step procedures for maintaining and troubleshooting the DVX.

**Section 6. Unit Documentation**, contains schematic diagrams, assembly drawings, and outline drawings for DIN and hockey-puck (HP) units.

The terms **NOTE**, **CAUTION**, and **WARNING** have the following definitions where used in this manual:

A **NOTE** contains additional information that makes it easier to perform a particular task. Failure to follow a note may result in some inconvenience or needless expense, but the unit will not be damaged, nor is the instrument technician likely to be injured.

A **CAUTION** stresses important details to follow when making electrical connections or cleaning PC board

contacts. Failure to heed a caution may damage the unit, void the Moore Industries warranty, or cause minor physical injury to the instrument technician.

A **WARNING** contains vital safety information that **MUST NOT** be ignored. Warnings deal with proper grounding of equipment, use of solvents, etc. Ignoring warnings may damage the unit, and risk personal injury, or even death, of the instrument technician.

### 1.1 DESCRIPTION

The DVX is a loop-powered, current-to-digital display indicator. It accepts either 4-20mA or 10-50mA current and activates corresponding digits of a liquid crystal digital display (LCD) of 0.35-inch black numerals.

The DVX is functionally based on a 2000-count, dual-slope, integrating analog-to-digital converter designed to reject interference signals normally found in industrial measurement environments.

The DVX is available in either a compact hockey-puck (HP) enclosure or a DIN rail mount housing for high density installations.

### 1.2 SPECIFICATIONS

Table 1-1 is a listing of DVX specifications. This table contains information on inputs, outputs, performance capabilities, and housing and electrical options.

### 1.3 MODEL NUMBER EXPLANATION AND USE

Moore Industries model numbers identify the instrument type, functional characteristics, operating parameters, and any configuration options the unit contained when it was initially shipped. If the documentation is missing, the model number can be used to obtain technical information on the unit. See the DVX model number example following table 1-1.

For HP units, the model number is stamped on a stainless steel tag fastened to the front of the module. For DIN units, the model number is located at the lower edge of the front panel.

Table 1-1. DVX Specifications

Characteristic	Specification
Input	<p>Current: 4-20mA or 10-50mA, jumper selectable</p> <p>Voltage Drop: 2.5 volts, maximum</p> <p>Protection: Maximum forward current overload: 0.2 amps</p> <p>Maximum reverse current: 1.0 amps</p> <p>Surge current: 2 amps for 2 microseconds, maximum, non-repetitive</p> <p>Common Mode Rejection Ratio (to case): 120dB</p> <p>Common Mode Voltage: 500 volts</p> <p>Normal Mode Rejection (@ 50/60 Hz): 46dB</p>
Display	<p>Type: LCD, 0.35-inch high black digits over reflective background</p> <p>Format: 3.5 active digits with selectable trailing dummy zero for scaling purposes</p> <p>Range: +1999 to -1999 (plus dummy zero as least significant digit)</p> <p>Decimal Points: 3 positions, jumper selectable</p> <p>Overrange: 3 least significant active digits blank out</p> <p>Rate: 2.5 readings per second</p> <p>Zero Offset: Zero may be offset by -2500 to +2500 counts (including dummy zero)</p> <p>Span Range: Can display any Zero Offset and Span to a maximum of 3.5 digit resolution (2000 counts); continuously adjustable up to 2000 counts from Zero Offset (Example: If Zero Offset is -250, Span can range from -250 to +1750)</p>
Power	Input power obtained from the signal input current loop
Adjustments	ZERO and SPAN: Front panel adjustable with multi-turn potentiometers (used in conjunction with jumper selectable OFFSET and SPAN Range to set operating configuration)
Operating Temperature	<p>Range: -40°C to +85°C (-40°F to +185°F)</p> <p>Effect: ±0.005% of span/°C, maximum</p>
Weight	454 grams (1 lbs)
Performance	Calibration Capability: ±0.1% of reading, ±1 count

DVX MODEL NUMBER EXAMPLE

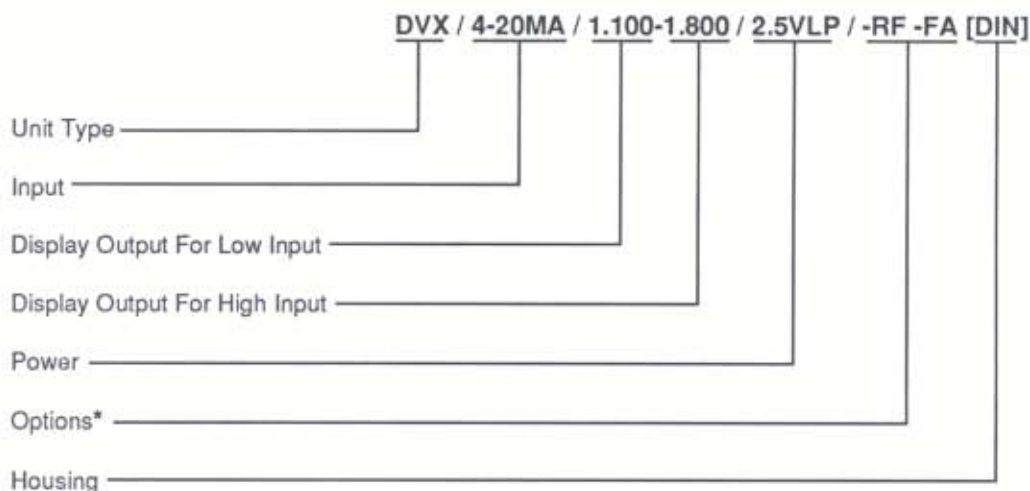

\* -FA option required on DIN units

## **SERIAL NUMBER USE AND LOCATION**

Moore Industries maintains a complete history on every unit it ships. This historical information is tracked by the unit serial number. If replacement of a unit is required,

or if historical data is needed, it will be necessary to provide the factory with the serial number and model number of the unit. The serial number is usually located adjacent to the model number.

## CALIBRATION PROCEDURES

### 2.0 CALIBRATION PROCEDURES

This section contains adjustment and calibration information for the DVX. Each unit is adjusted and checked at the factory for proper performance prior to shipment. However, input and output values for each unit should be checked, on site, before the equipment is placed into service. Refer to paragraph 1.3 and table 1-1, section 1.0, for minimum and maximum input and output values.

#### 2.1 GENERAL INFORMATION

After unpacking the DVX, general operating level checks are recommended using the calibration procedures described in this section.

#### 2.2 CONTROL DESCRIPTION AND LOCATION

ZERO and SPAN adjustments are located on the front panel of the DVX. The external controls are multi-turn potentiometers that are adjusted with a slotted screwdriver.

#### CAUTION

Use of a screwdriver having a head width greater than 2.54mm (0.1 in.) may permanently damage the potentiometer mounting. When adjusting a RF-optional unit, a screwdriver with a plastic shank must be used. A metal shank tool can circumvent the RF immunity and compromise the adjustment.

#### 2.3 TEST EQUIPMENT AND TOOLS REQUIRED

The test equipment and tools required for calibrating the DVX are listed in table 2-1. These items are not supplied with the unit, and therefore must be furnished by the user.

#### 2.4 CALIBRATION SETUP

Figure 2-1 illustrates the calibration setup for the DVX. Terminal connections are shown on the outline drawing in section 6, and are identifiable on the actual unit.

### 2.5 JUMPER CONFIGURATIONS

To access the field selectable jumpers on a HP unit, you must first; remove the four (4) screws from the front panel of the module, and then; lift out the front panel display, along with the two attached printed circuit boards. (see figure 2-2) The HP unit has 90-degree angle pin connectors for jumper settings.

To access the field selectable jumpers on a DIN unit, remove the six (6) screws from the right-side panel. (see figure 2-2) The DIN unit has standard straight pin connectors for jumper settings.

There are 9 jumpers that may be installed in any of 24 positions on 2 connector blocks. For both the HP and the DIN units, one connector block has a single row of pins; the other connector block has a double row of pins. The single row connector block accepts jumpers that select a decimal point position, a trailing dummy zero, and a minus sign. The double row connector block accepts jumpers that select input current, display count range, display count sensitivity, and zero offset range.

For the single row connector blocks, the jumpers are stored by plugging them into one pin only, as shown in figure 2-3.

For the double row connector, the jumpers are stored on one pin, as shown in figure 2-4.

For the single row connector block, the active functions are selected by installing jumpers as shown in figure 2-5.

#### NOTE

Only one decimal position jumper should be in an active position at any one time.

For the double row connector block, the active functions are selected by installing jumpers as shown in figures 2-6A and 2-6B. (Note: All possible active positions are shown in these figures, but no more than six of these positions are ever used at any one time.)

## CALIBRATION PROCEDURES

### 2.0 CALIBRATION PROCEDURES

This section contains adjustment and calibration information for the DVX. Each unit is adjusted and checked at the factory for proper performance prior to shipment. However, input and output values for each unit should be checked, on site, before the equipment is placed into service. Refer to paragraph 1.3 and table 1-1, section 1.0, for minimum and maximum input and output values.

#### 2.1 GENERAL INFORMATION

After unpacking the DVX, general operating level checks are recommended using the calibration procedures described in this section.

#### 2.2 CONTROL DESCRIPTION AND LOCATION

ZERO and SPAN adjustments are located on the front panel of the DVX. The external controls are multi-turn potentiometers that are adjusted with a slotted screwdriver.

#### CAUTION

Use of a screwdriver having a head width greater than 2.54mm (0.1 in.) may permanently damage the potentiometer mounting. When adjusting a RF-optional unit, a screwdriver with a plastic shank must be used. A metal shank tool can circumvent the RF immunity and compromise the adjustment.

#### 2.3 TEST EQUIPMENT AND TOOLS REQUIRED

The test equipment and tools required for calibrating the DVX are listed in table 2-1. These items are not supplied with the unit, and therefore must be furnished by the user.

#### 2.4 CALIBRATION SETUP

Figure 2-1 illustrates the calibration setup for the DVX. Terminal connections are shown on the outline drawing in section 6, and are identifiable on the actual unit.

### 2.5 JUMPER CONFIGURATIONS

To access the field selectable jumpers on a HP unit, you must first; remove the four (4) screws from the front panel of the module, and then; lift out the front panel display, along with the two attached printed circuit boards. (see figure 2-2) The HP unit has 90-degree angle pin connectors for jumper settings.

To access the field selectable jumpers on a DIN unit, remove the six (6) screws from the right-side panel. (see figure 2-2) The DIN unit has standard straight pin connectors for jumper settings.

There are 9 jumpers that may be installed in any of 24 positions on 2 connector blocks. For both the HP and the DIN units, one connector block has a single row of pins; the other connector block has a double row of pins. The single row connector block accepts jumpers that select a decimal point position, a trailing dummy zero, and a minus sign. The double row connector block accepts jumpers that select input current, display count range, display count sensitivity, and zero offset range.

For the single row connector blocks, the jumpers are stored by plugging them into one pin only, as shown in figure 2-3.

For the double row connector, the jumpers are stored on one pin, as shown in figure 2-4.

For the single row connector block, the active functions are selected by installing jumpers as shown in figure 2-5.

#### NOTE

Only one decimal position jumper should be in an active position at any one time.

For the double row connector block, the active functions are selected by installing jumpers as shown in figures 2-6A and 2-6B. (Note: All possible active positions are shown in these figures, but no more than six of these positions are ever used at any one time.)

Equipment	Characteristic	Purpose
Blade Screwdriver	Blade not wider than 2.5mm (0.1 inch)	To adjust ZERO and SPAN pots
Adjustable Precision Current Source	0 to 50mA dc accurate to within $\pm .05\%$ or better with $V_c$ not less than 2.5Vdc	To provide input signal

\* $V_c$  = compliance voltage

Table 2-1 Test Equipment and Tools Required

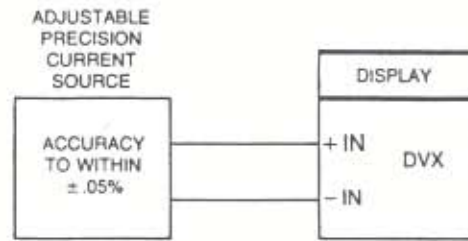

Figure 2-1 Test Set-Up

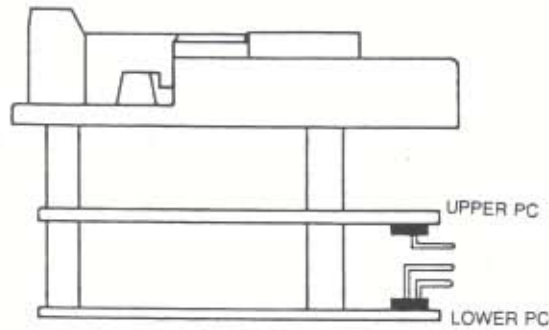

Figure 2-2 DVX Unit Disassembly

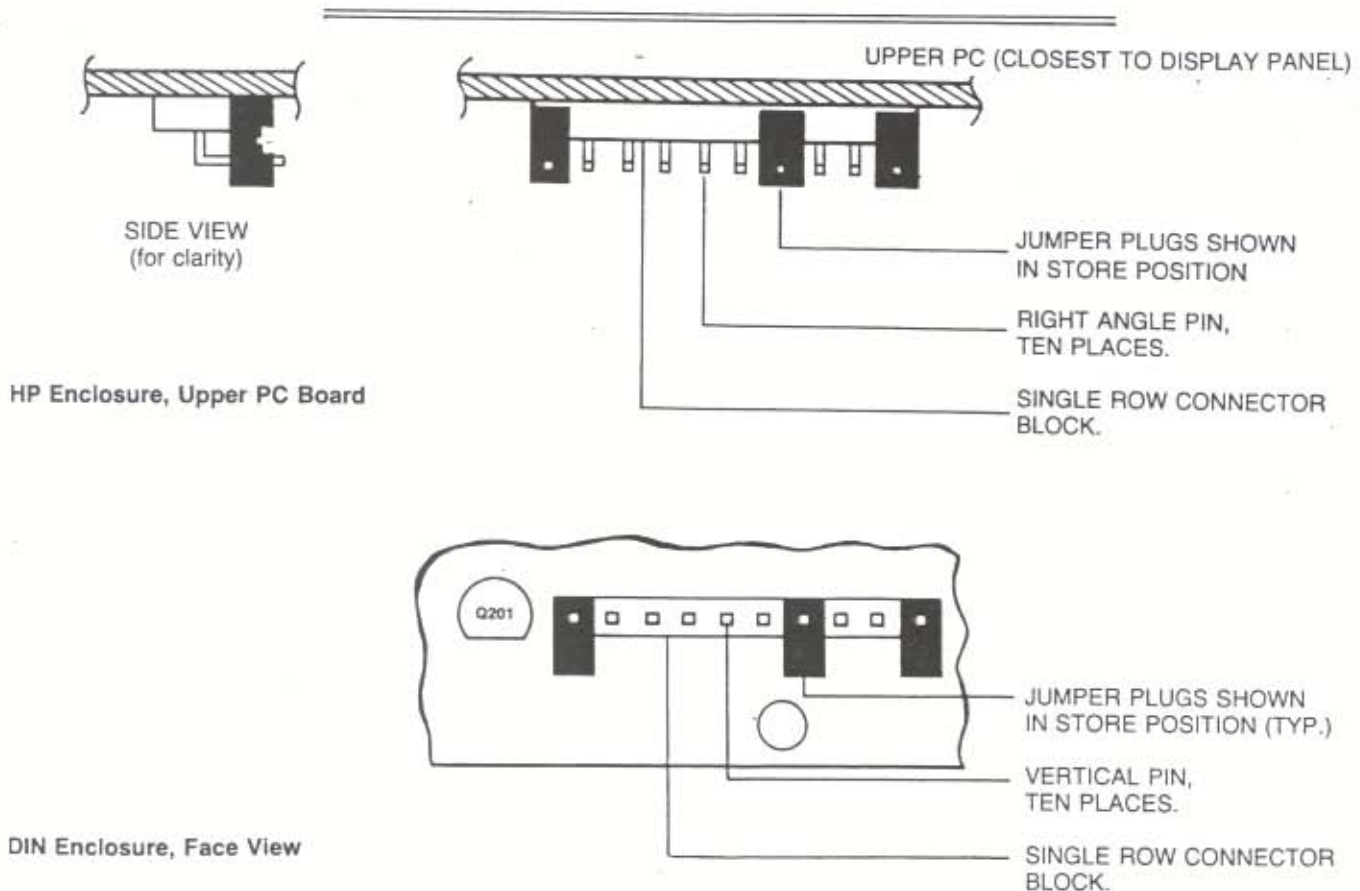

Figure 2-3 Jumper Storage Positions For Single Row Connector

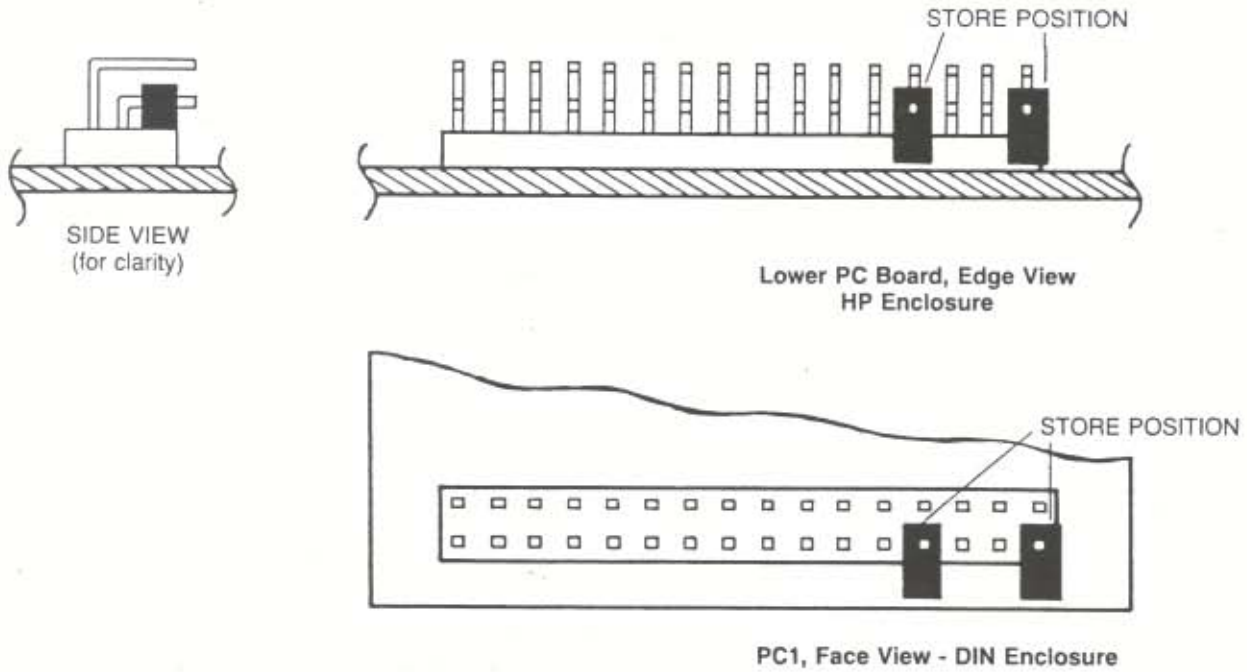

Figure 2-4  
Jumper Storage Positions for  
Double Row Connectors

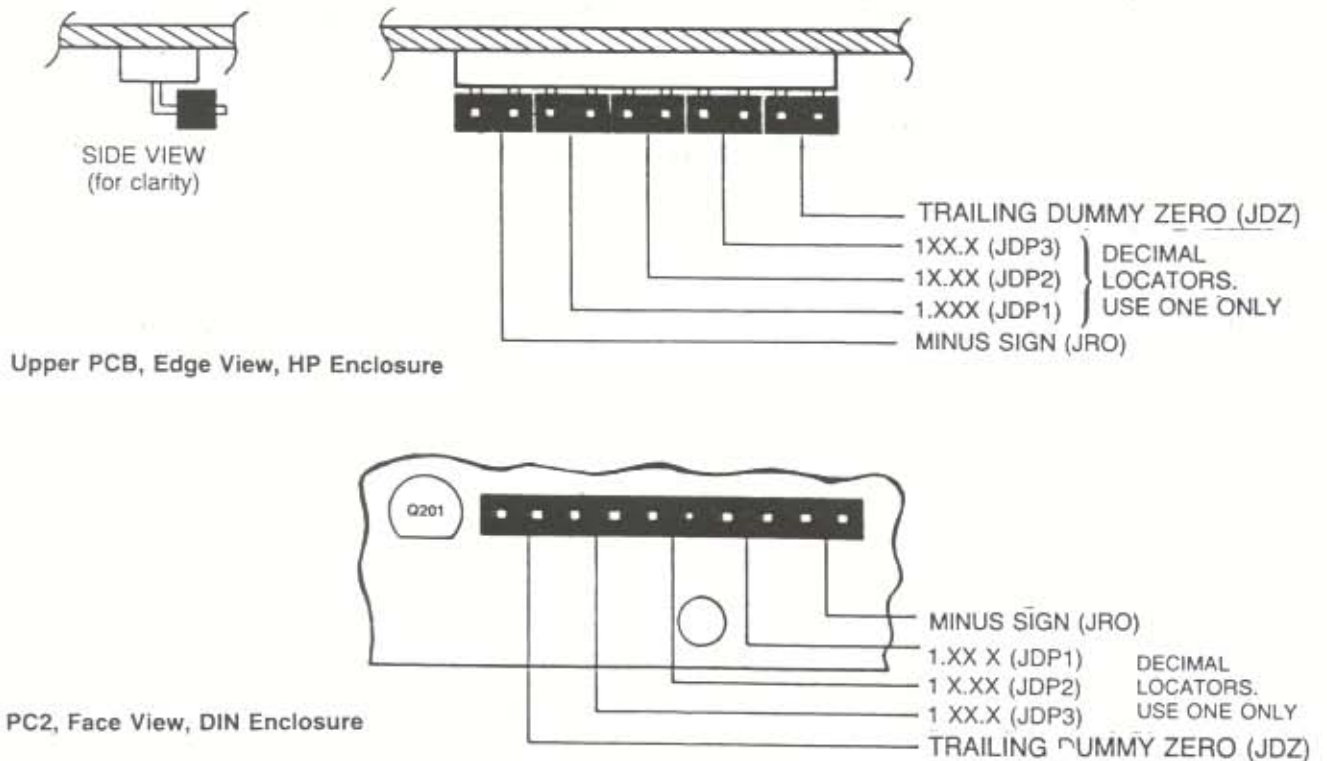
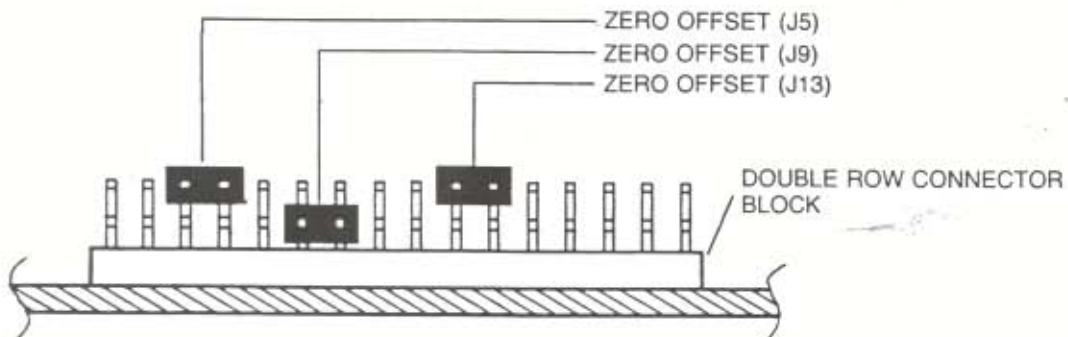
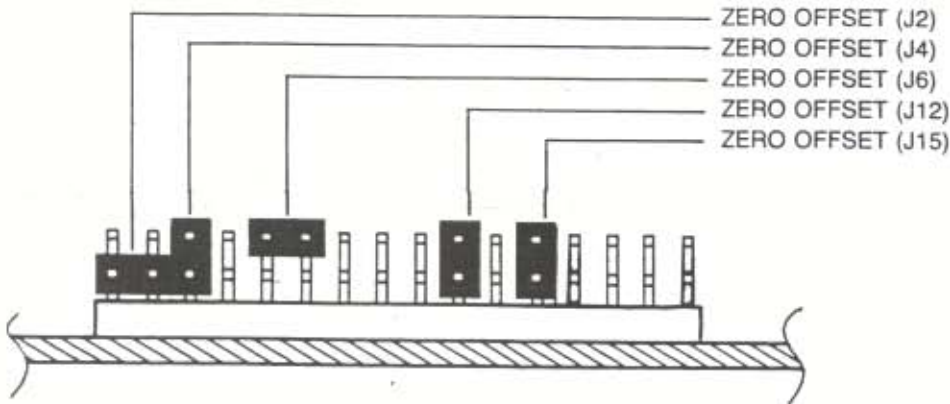
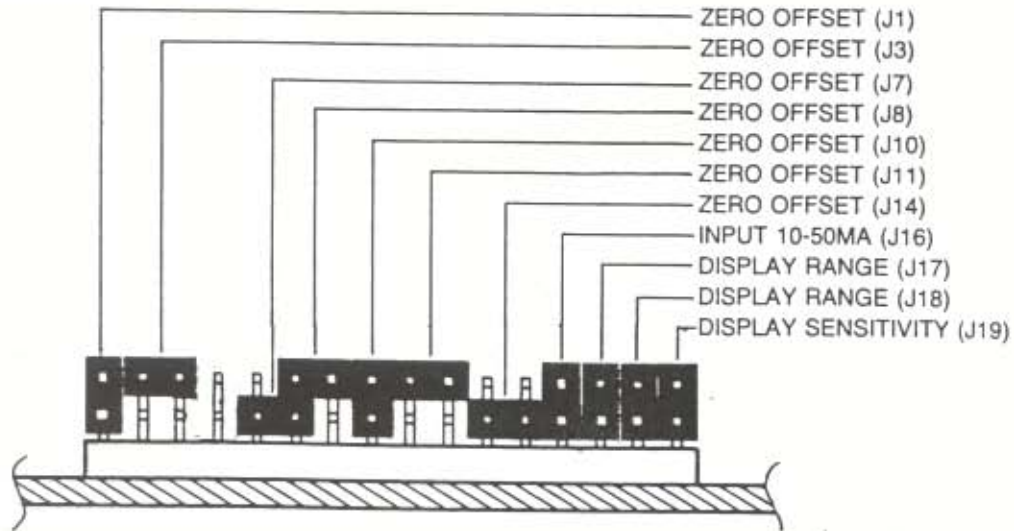

Figure 2-5  
Single Row Connector, Jumper Positions For Active Functions



Lower PC Board, Edge View



NO MORE THAN SIX JUMPER PLUGS ARE EVER USED IN THE ACTIVE POSITION AT ANY ONE TIME ON THIS BOARD.

Figure 2-6A  
Double Row Connector, Jumper Positions  
For Active Functions, HP Enclosure

Lower PC Board, Edge View

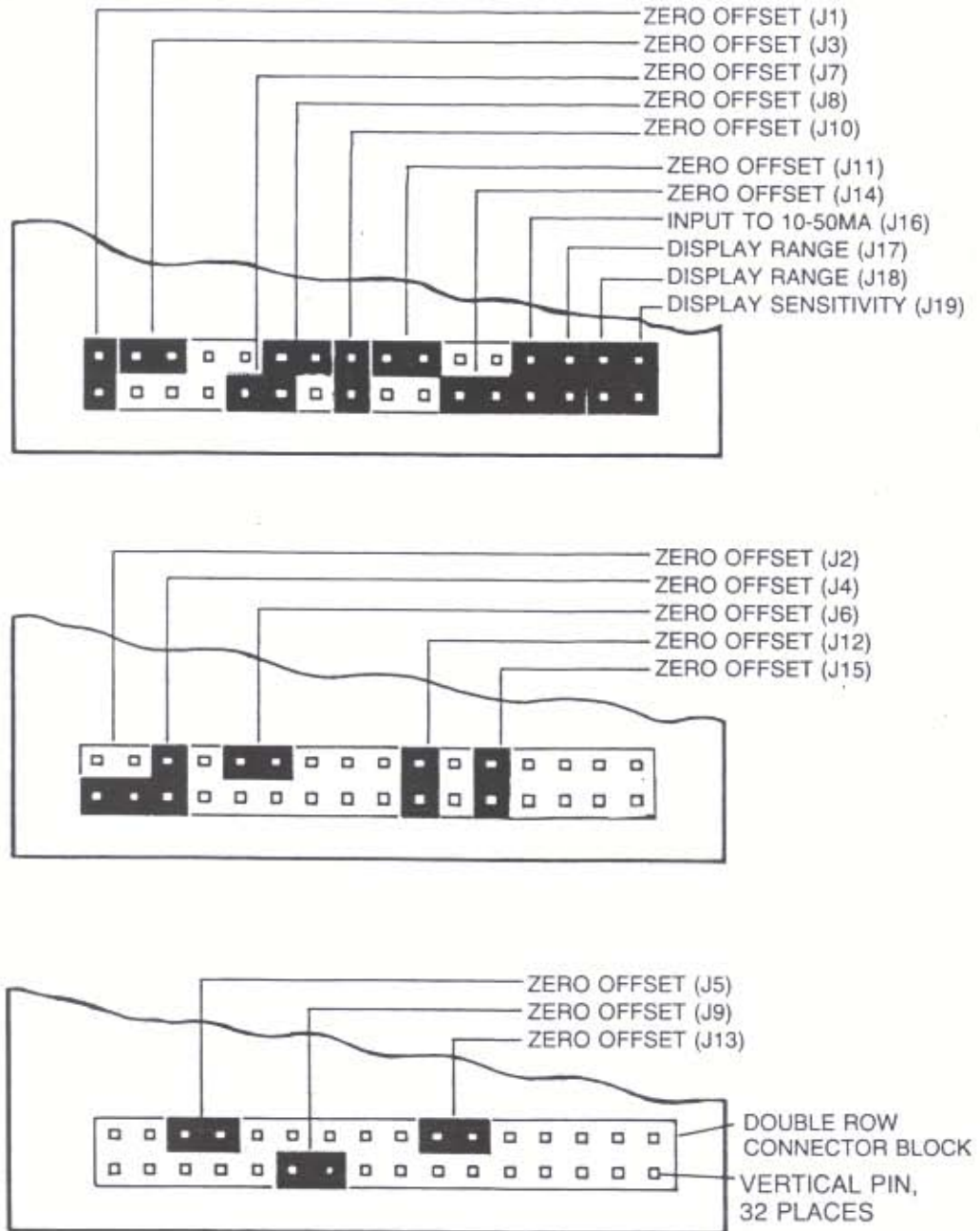

NO MORE THAN SIX JUMPER PLUGS ARE EVER USED IN THE ACTIVE POSITION AT ANY ONE TIME ON THIS BOARD.

Figure 2-6B  
Double Row Connector, Jumper Positions  
For Active Functions, DIN Enclosure

### 2.5.1 INPUT JUMPER CONFIGURATION

If the input is to be a 4-20mA loop, remove jumper J16. If the input is a 10-50mA loop, install J16.

### 2.5.2 SENSITIVITY JUMPER CONFIGURATION

1. Determine range of current to be measured (i.e.,  $I_{max} - I_{min}$ ).
2. Determine the minimum and maximum counts to be displayed. (The total display range is -1999 to +1999; the minimum and maximum display counts plus any added offset must fall within the range of these figures.)
3. Determine sensitivity required of the DVX.

If:  $A = I_{max} - I_{min}$ , AND  
 $B = (\text{max display count}) - (\text{min display count})$ ,  
then the sensitivity required is:  $C = B/A$ .

Several different actions are required, depending on the value of C:

If C is negative, install jumper J10. See figure 2-5.

If absolute value of C is 125 or less, remove jumper J19. Otherwise install J19.

If absolute value of C is 125 or less and B (display range) is less than 1000 or absolute value of C is greater than 125 and B is less than 2000, install J17 and remove J18. Otherwise, remove J17 and install J18 (jumpers J17 and J18 select sensitivity ranges).

#### Zero Offset Jumper Configuration

The ZERO potentiometer allows for a 1000 count adjustment of the display. The offset jumper selection must therefore be such that the desired display count at minimum current falls within the adjustable range at the ZERO potentiometer.

First find the display adjustment required. With no offset the display would read:

$D = \text{display count}$   
 $D = (I_{min}) \times C$ ,  
where  $I_{min}$  is the minimum current  
and C is the value obtained in  
2.5.2, step 3.

This reading must now be offset to obtain the desired reading.

If the desired display count at  $I_{min}$  is X, then the jumper selection must be such that an offset of  $E = X - D$  is introduced.

If jumper J19 has been installed, this value of E should be multiplied by 2.

The jumper selections may be obtained from tables 2-7 and 2-8 (use table 2-7 if C is positive and 2-8 if C is negative).

Example:

Assume a 4-20mA loop with 4mA corresponding to a display of 0, and 20mA corresponding to a display of 1200;

1. For a 4-20mA loop, remove J16
2. Current range  $A = 20 - 4 = 16$
3. Display range  $B = 1200 - 0 = 1200$
4. Sensitivity  $C = B/A = 1200/16 = 75$

C is less than 125 and B is greater than 1000; therefore, remove J17 and install J18. Also, since C is less than 125, J19 should be removed.

5.  $D = 4 \times 75 = 300$   
 $E = X - 300$

### 2.5.3 DECIMAL LOCATION

To select a decimal point location, install jumper JDP1, 2, or 3 as shown in figure 2-5.

### 2.5.4 TRAILING DUMMY ZERO

For a trailing dummy zero in the display, install jumper JDZ as shown in figure 2-5.

## 2.6 ZERO AND SPAN ADJUSTMENT

1. Set the input current to 0%. Adjust the ZERO potentiometer to read the desired minimum value on the display.
2. Set the input current to 100%. Adjust the SPAN potentiometer to read full scale engineering units on the display. Verify that the polarity and decimal point indications are correct.
3. Repeat steps 1 and 2 until no further adjustments are necessary.

<b>Range of E</b>	<b>Jumper Plugs Required</b>
-500 to +500	J3, J9, J13
0 to +1000	J2, J9, J12
+500 to +1500	J1, J9, J11
+1000 to +2000	J1, J8, J11
+1500 to +2500	J1, J10, J11
0 to -1000	J4, J9, J15
-500 to -1500	J5, J9, J14
-1000 to -2000	J5, J6, J14
-1500 to -2500	J5, J7, J14

For the range of E used, remove any jumpers between J1 and J15 NOT specified here.

**Figure 2-7**  
For use when C is POSITIVE

<b>Range of E</b>	<b>Jumper Plugs Required</b>
-500 to +500	J3, J9, J13
0 to +1000	J4, J9, J15
+500 to +1500	J5, J9, J14
+1000 to +2000	J5, J6, J14
+1500 to +2500	J5, J7, J14
0 to -1000	J2, J9, J12
-500 to -1500	J1, J9, J11
-1000 to -2000	J1, J8, J11
-1500 to -2500	J1, J10, J11

For the range of E used, remove any jumpers between J1 and J15 NOT specified here.

**Figure 2-8**  
For use when C is NEGATIVE

## **INSTALLATION & OPERATION**

### **3.0 INSTALLATION & OPERATION**

The DVX is available in two types of housings; the hockey-puck (HP) and the DIN rail-mount. Section 6 contains the outline dimension drawings for both HP- and DIN-type units. Refer to these drawings when preparing for installation of the DVX.

#### **3.1 MECHANICAL INSTALLATION**

Select the applicable outline dimension drawing in section 6. Review the drawing carefully, along with any accompanying notes, to ensure a thorough understanding of installation criteria.

Although the DVX is designed for convection cooling, it is advisable to mount the unit on a surface that will aid in the dissipation of heat. Also, the unit should be installed in an area where it will be protected from dust, moisture, and corrosive elements.

#### **3.2 ELECTRICAL CONNECTIONS**

The connections for the two inputs (+IN and -IN) required to drive the DVX are shown in the outline dimen-

sion drawing in section 6, and are clearly marked on the unit itself. For both HP and DIN units the connections are made on the front of the unit where indicated.

No special wire or cable is required to complete the power loop. It is recommended however, that #20 AWG wire be used when connecting to the compression screw terminals of the DVX. No terminal lugs are necessary for this type of terminal. To secure the connections to the DVX, strip the insulation from the end of the wire, tin the ends with 60/40 solder, insert the wire in the designated terminal socket, and tighten the associated screw.

#### **3.3 OPERATION**

For proper operation, the DVX needs a minimum of 2.5Vdc from the current loop. Once installed and operating, it is unlikely that further adjustments will be necessary. Reading the visual display is the only user intervention required. Because the DVX utilizes highly reliable solid-state components, the unit should operate maintenance free for extended periods of time.

## THEORY OF OPERATION

### 4.0 THEORY OF OPERATION

This section briefly describes the theory of operation for the DVX, based on the block diagram in figure 4-1. The purpose of this description is to show how signals are processed through the unit should it become necessary to troubleshoot the loop. Section 6 contains detailed schematic diagrams for both the HP and DIN units.

### 4.1 OPERATION

The current input signal to the DVX is measured as the voltage across a current sense resistor in series with the "-IN" terminal. The voltage is doubled to approximately 5 volts by the power supply. The offset circuit uses  $\pm 1.2V$  references to provide different offset voltages. The input signal and offset voltage are applied to the analog-to-digital converter, which generates the display signals for the liquid-crystal, digital display.

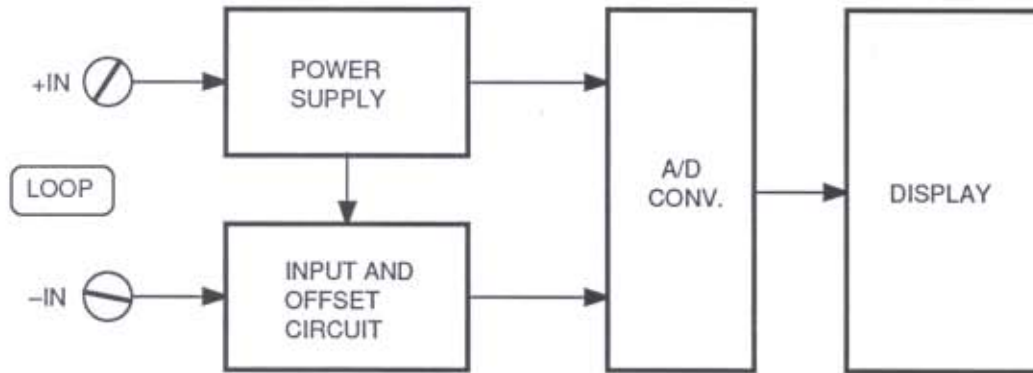

Figure 4-1  
DVX Block Diagram

## **MAINTENANCE & TROUBLESHOOTING**

### **5.0 MAINTENANCE AND TROUBLESHOOTING**

#### **5.1 MAINTENANCE**

The design of the DVX limits maintenance primarily to keeping the input and output terminals and conductors clean and tight, while maintaining a good heat conduction path to a suitable heat sink. This is best accomplished by initially tinning the ends of all hook-up wires, as described in section 3.0. It is recommended that the user check the terminations every six months of service.

#### **5.2 TROUBLESHOOTING**

If a problem is suspected with the DVX, check the following procedures:

1. If the relationship between the input and the output (display) changes, readjust the SPAN and ZERO potentiometers (see paragraph 2.6).
2. Verify that the input terminals are clean and tight.
3. Verify that the selected jumpers are properly installed, in accordance with paragraph 2.5.

If these steps fail to restore normal performance to the DVX, the unit may be defective and should be returned to the factory in accordance with the instructions on the back cover of this manual.

# UNIT DOCUMENTATION

## 6.0 UNIT DOCUMENTATION

This section contains schematic diagrams, assembly drawings, and outline dimension drawings for both the

HP and the DIN units. These illustrations may be helpful when calibrating and installing the DVX.

### HOCKEY-PUCK HOUSING

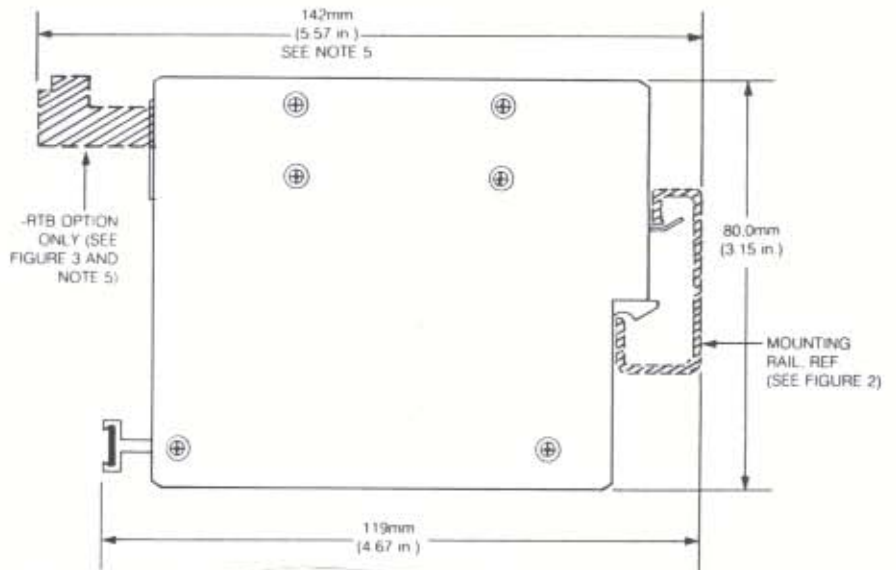
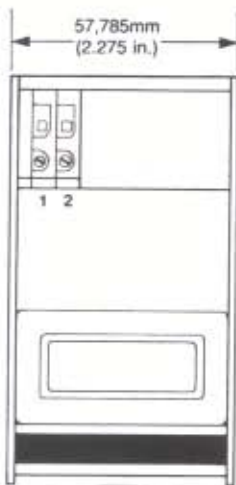
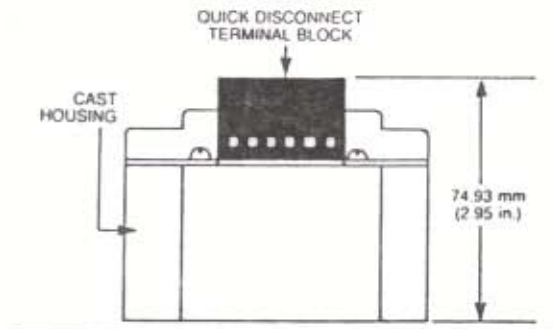
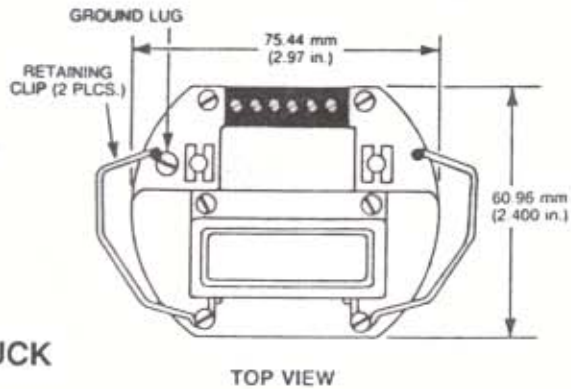





**MOORE INDUSTRIES**  
16650 Schoenborn Street  
Sepulveda, California 91343

**DO NOT SCALE DRAWING**

TOLERANCES  
UNLESS NOTED  
X ±.1  
XX ±.03  
XXX ±.010  
ANGLES ±30°

DRAWN  
*Ken Kelley*  
CHECKED  
DESIGNED  
*J. GOUGH*  
SCALE

*DVX-HP*  
*PC1 & PC2*

DRAWING NUMBER

*178-401-00*

REVISION

*E*

CATEGORY

*SCHEMATIC*

REVISED BY

*ECG 6391*

DATE

*8/27/67*

BY

*ECG*

APPROVAL

*[Signature]*

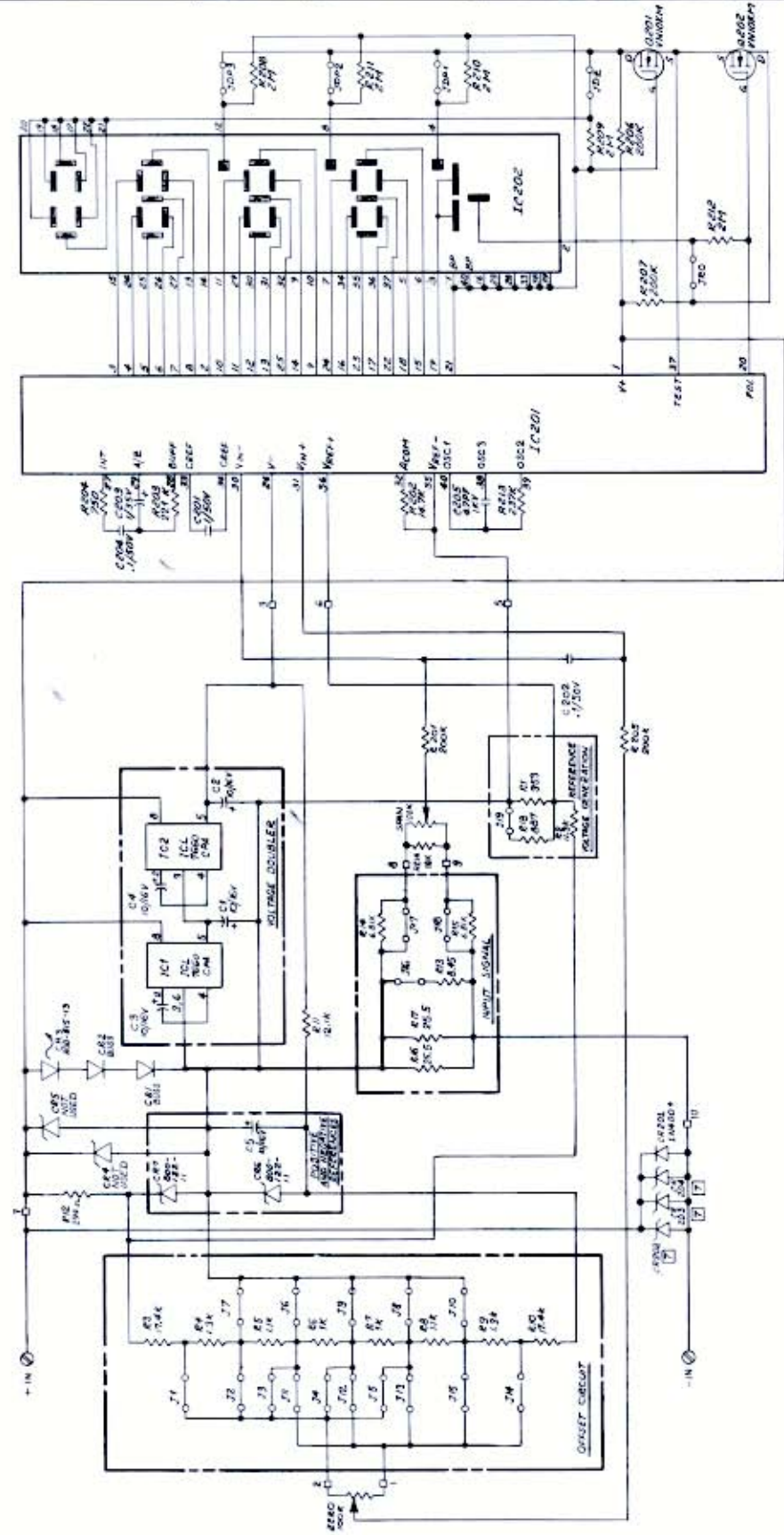

- 1. RESISTORS ARE METAL FILM (RMS) 1%, 50 W.
  - 2. RESISTORS ARE METAL FILM (RMS) 1%, 50 W.
  - 3. SPAN & ZERO ARE MOUNTED ON PCB.
  - 4. SCREEN TERMINAL POSITION ON FRONT PANEL.
  - 5. SCREEN TERMINAL POSITION ON FRONT PANEL.
  - 6. SPAN & ZERO ARE MOUNTED ON PCB.
  - 7. RESISTORS ARE METAL FILM (RMS) 1%, 50 W.
  - 8. RESISTORS ARE METAL FILM (RMS) 1%, 50 W.
- NOTES: UNLESS OTHERWISE SPECIFIED.

**MOORE INDUSTRIES**  
 16650 Schoenborn Street  
 Sepulveda, California 91343

**DO NOT SCALE DRAWING**  
 TOLERANCES UNLESS NOTED  
 X ± .1  
 XX ± .03  
 XXX ± .010  
 ANGLES ± 30°  
 DRAWN *R. Kelley* 3/84  
 CHECKED  
 TITLED  
 SCALE 2-1

**DVX  
 PCI**

Drawn by: *SHT*  
 178-501-00 1 of 2 C  
 CATEGORY: **PC ASSEMBLY**  
 REVISED BY: *ECO* 6000  
 BY: *JVN*  
 DATE: *1/84*

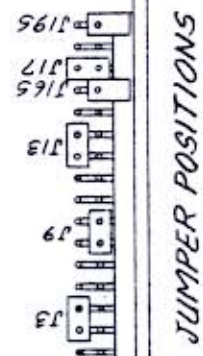
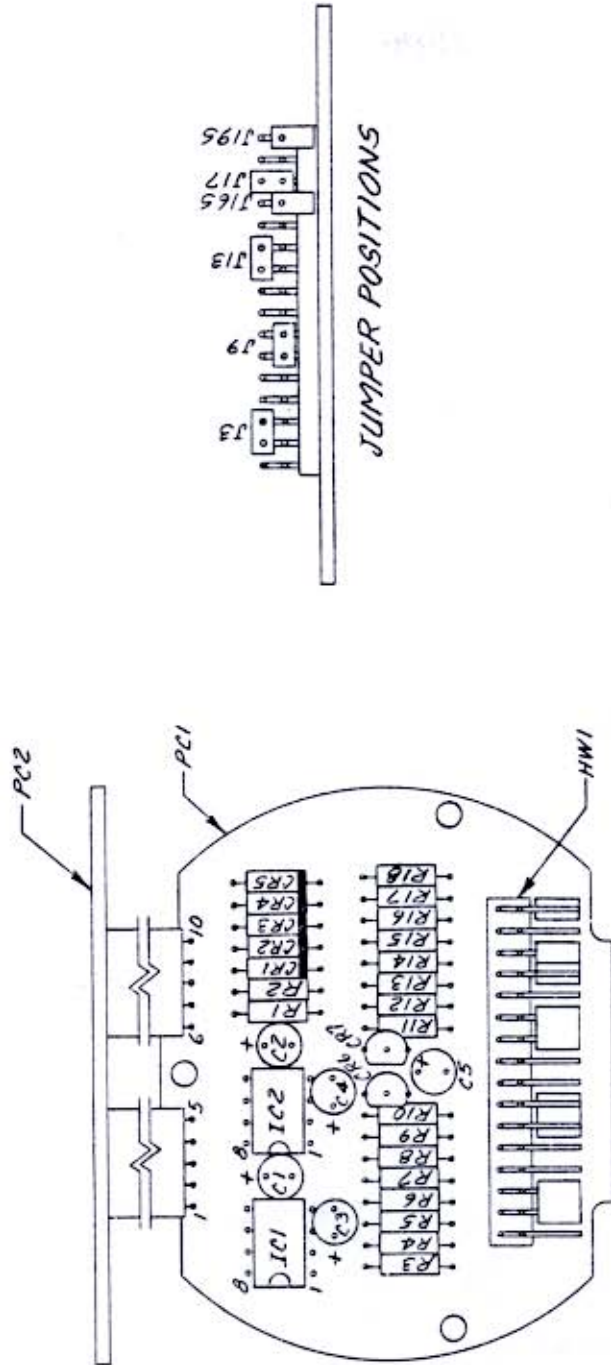

2. J13, J19, J13, J165, J17 & J195 ARE PLUG-ON JUMPERS.  
 PLUG ON TO POSITIONS SHOWN.  
 1. ALL LEADS TO BE SOLDERED TO PADS, FAR SIDE.  
**NOTES: UNLESS OTHERWISE SPECIFIED**



**MOORE INDUSTRIES**  
16650 Schoenborn Street  
Sepulveda, California 91343

DO NOT SCALE DRAWING

TOLERANCES  
UNLESS NOTED  
X ±.1  
XX ±.03  
XXX ±.010  
ANGLES ±30°

DRAWN P. Kelly 7/1/80  
CHECKED  
ENGINEER  
SCALE 2-1

FRONT PANEL  
DVX-HP  
PC1

DRAWING NUMBER 178-501 00  
REV 2 OF 2  
CATEGORY ASSEMBLY, P.C.  
REVISED BY ECO 6000  
DATE 2/81/86  
BY JUV  
APPROVAL

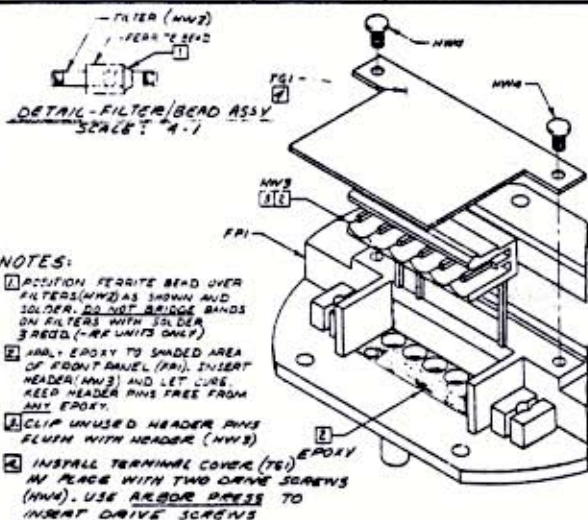

STEP ONE

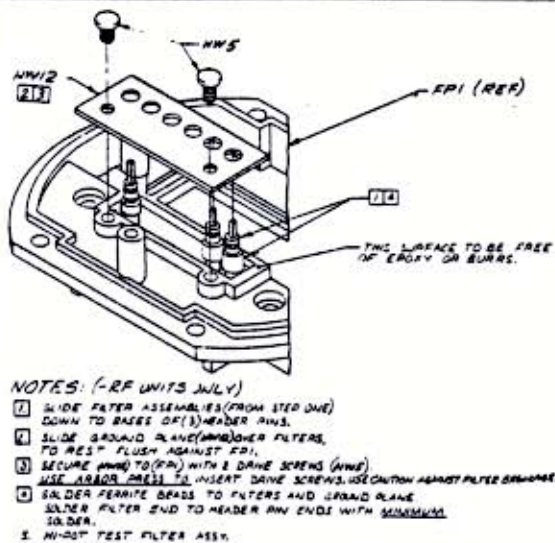

STEP TWO

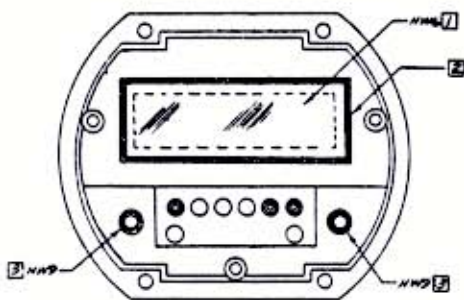

STEP THREE

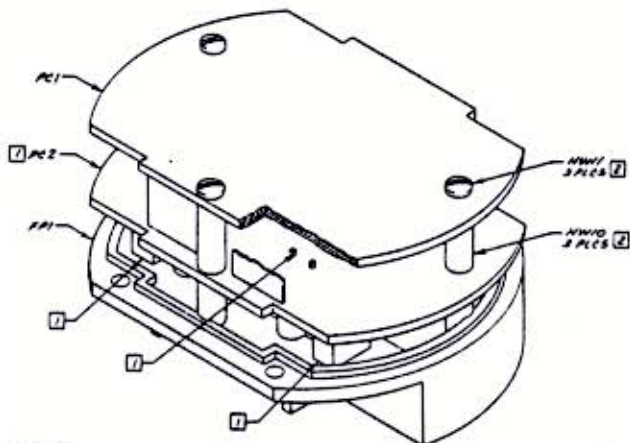

STEP FOUR

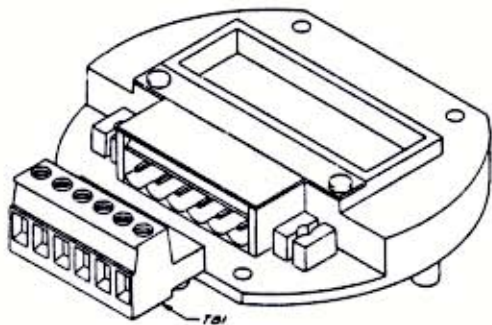

STEP FIVE

DO NOT SCALE DRAWING

TOLERANCES	UNLESS NOTED
XX	+1
XXX	+0.3
ANGLES	+30
DRAWN	R. Kelley
CHECKED	
DESIGNED	J. GOUGH
DATE	2-1

DVX  
PC2

BRAND NUMBER	178-502-00	REV. C/D	D
CATEGORY	PC ASSEMBLY		
REVISED BY	ECO 6391	DATE	12/16

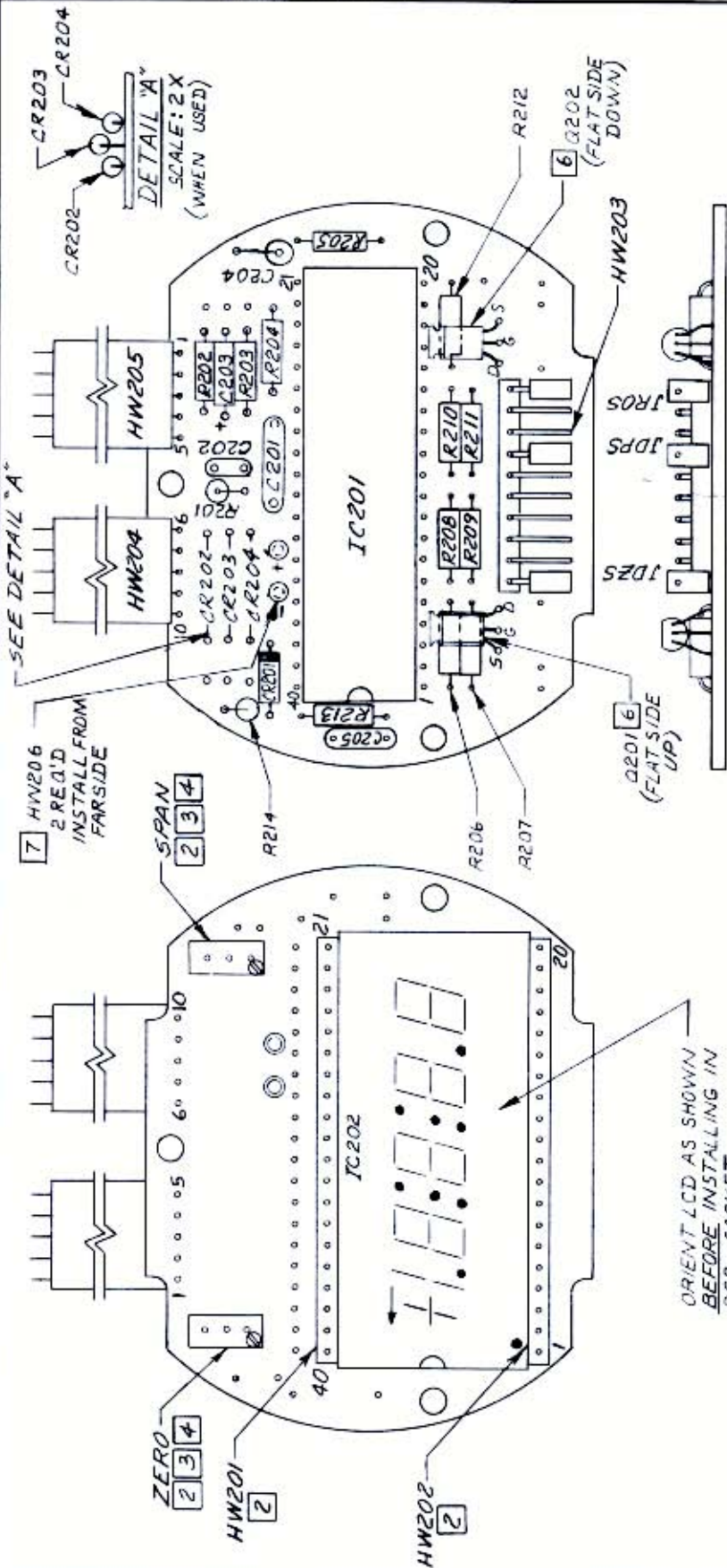

**JUMPER POSITIONS**

7. SOCKET OPENING TO BE FREE OF SOLDER.
6. SLEEVE Q201 & Q202 .062 BEYOND METAL TAB, THEN BEND OVER, MAKING SURE THE TABS DONOT TOUCH LEADS OF IC201.
5. J205, J203 & J204 ARE PLUG-ON JUMPERS, PLUG ON POSITIONS SHOWN.
4. USE TOOLING FIXTURE 178-202-01 TO HOLD ZERO & SPAN WHILE SOLDERING.
3. ZERO & SPAN MUST SIT FLAT ON & PERPENDICULAR TO PCB BOARD.
2. INSTALL ZERO, SPAN, HW201 & HW202 BEFORE ANY OTHER COMPONENTS.
1. ALL LEADS TO BE SOLDERED TO PADS.

NOTES: UNLESS OTHERWISE SPECIFIED.



**MOORE INDUSTRIES**  
16650 Schoenborn Street  
Sepulveda, California 91343

**DO NOT SCALE DRAWING**

**TOLERANCES**  
UNLESS NOTED  
X ± 1  
.XX ± 0.3  
.XXX ± 0.10  
ANGLES ± 30°

REV	DATE	BY	CHKD
1	7/14/84		
2	7/14/84		

DESIGNED BY: [Signature]  
CHECKED BY: [Signature]  
SCALE: NONE

DVX - DIN  
PC1A PCB

DRAWING NUMBER  
175-405-117

CATEGORY  
SCHEMATIC

REVISED BY  
GTT/299

DATE  
7/15/84

BY  
GTT

APPROVAL  
[Signature]

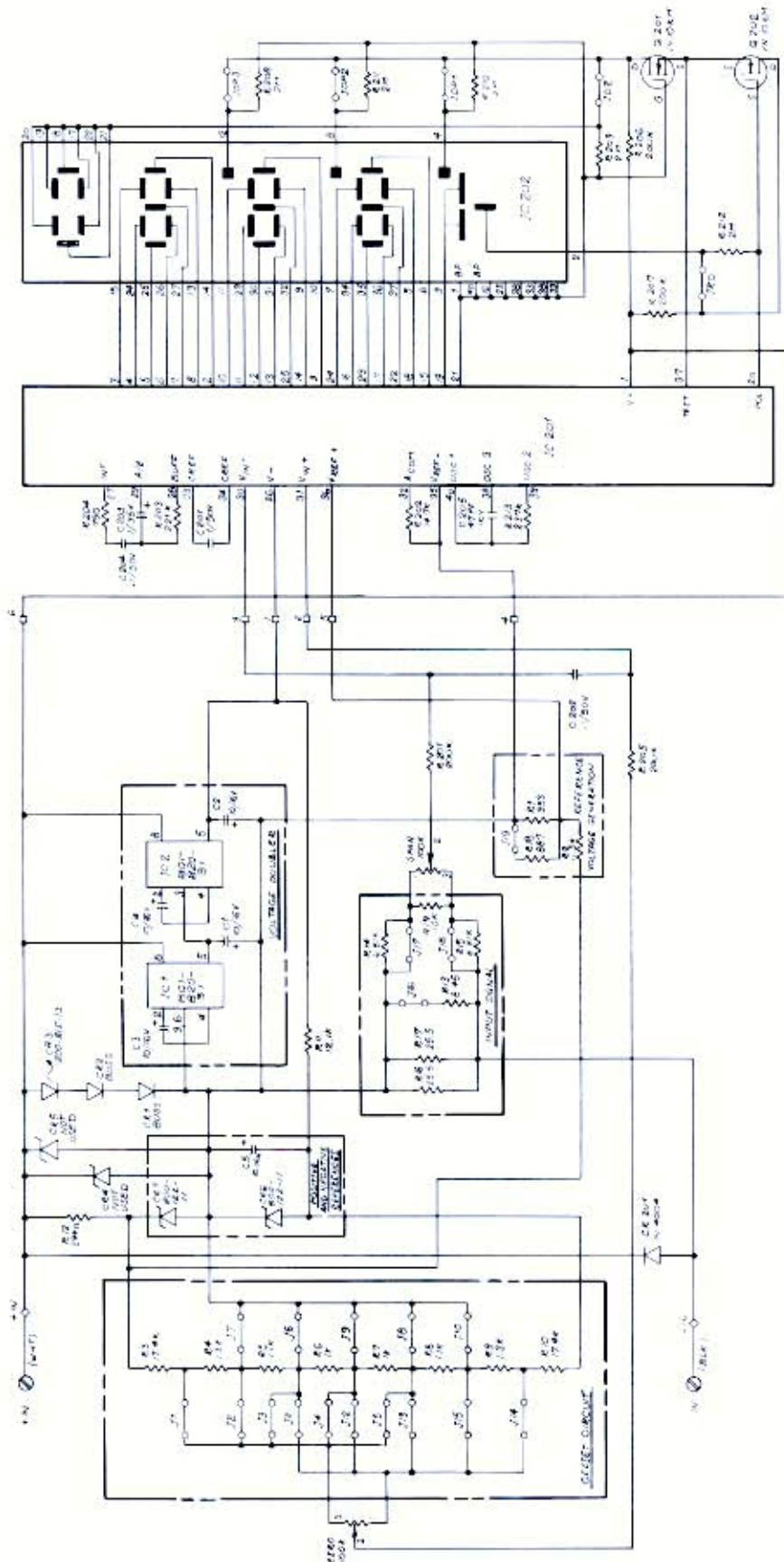

1. DIRECT CIRCUIT
2. VOLTAGE DOUBLER
3. OUTPUT STAGE
4. 5V SUPPLY
5. 0V SUPPLY
6. RESISTOR AND DIODE NETWORK
7. RESISTOR AND DIODE NETWORK
8. RESISTOR AND DIODE NETWORK
9. RESISTOR AND DIODE NETWORK
10. RESISTOR AND DIODE NETWORK

NOTE:



**MOORE INDUSTRIES**  
16650 Schoenborn Street  
Sepulveda, California 91343

**DO NOT SCALE DRAWING**

TOLERANCES  
UNLESS NOTED  
X ± .1  
XX ± .03  
XXX ± .010  
ANGLES ± 30°

DESIGNED BY *R. Kelley* 8/84  
CHECKED  
DRAWN  
DATE *2-1*

**DVX-DIN**  
**PC2**

DRAWING NUMBER  
**178-506-00**

REVISION  
**B**

CATEGORY  
**PC ASSEMBLY**

REVISED BY  
**ECO 5876**

DATE  
*8/18/84*  
BY  
*JKG*  
APPROVAL  
*JKG*

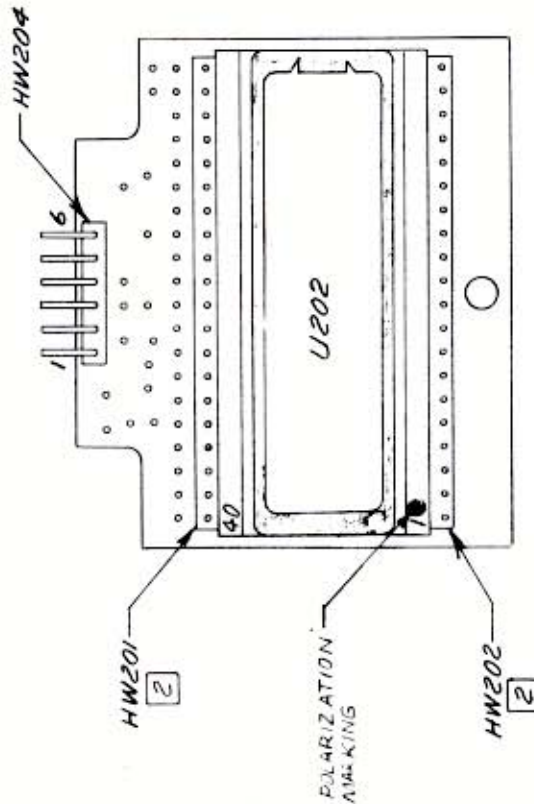
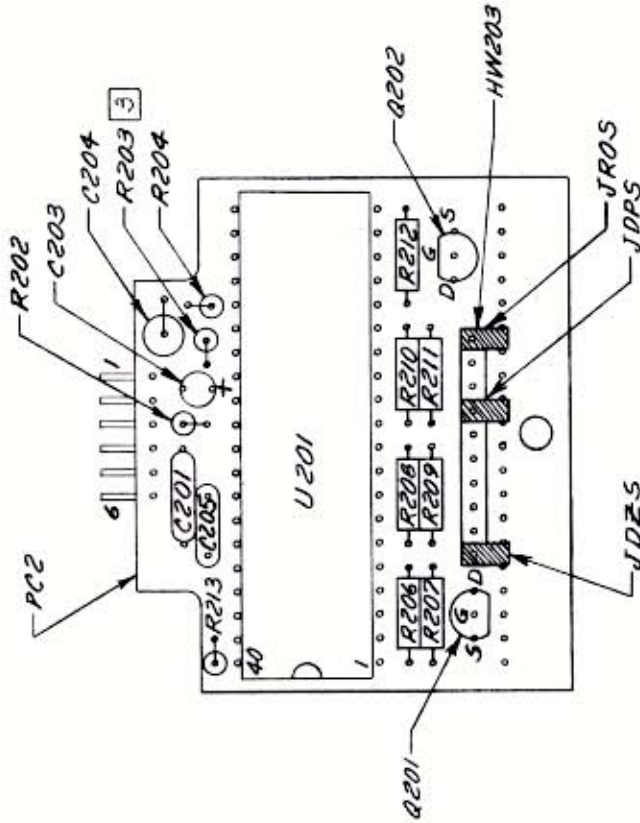

4. JUMPERS PLUG ON TO HW203 IN POSITIONS SHOWN.  
 3. SLEEVE LEADS OF ALL STAND-UP COMPONENTS.  
 2. INSTALL HW201 & HW202 BEFORE OTHER COMPONENTS.  
 1. ALL LEADS TO BE SOLDERED TO PADS.  
 NOTES: UNLESS OTHERWISE SPECIFIED.

DO NOT SCALE DRAWING

TOLERANCES  
UNLESS NOTED  
X ±.1  
XX ±.03  
XXX ±.010  
ANGLES ±30

DESIGNED BY R. Kelley 8/84  
CHECKED  
APPROVED  
DATE 2-1

# DVX-DIN PCI

REVISED BY

178-505-00

REVISED BY

PC ASSEMBLY

REVISED BY  
ECO 6290

DATE 7/2/94  
BY  
CHECKED BY

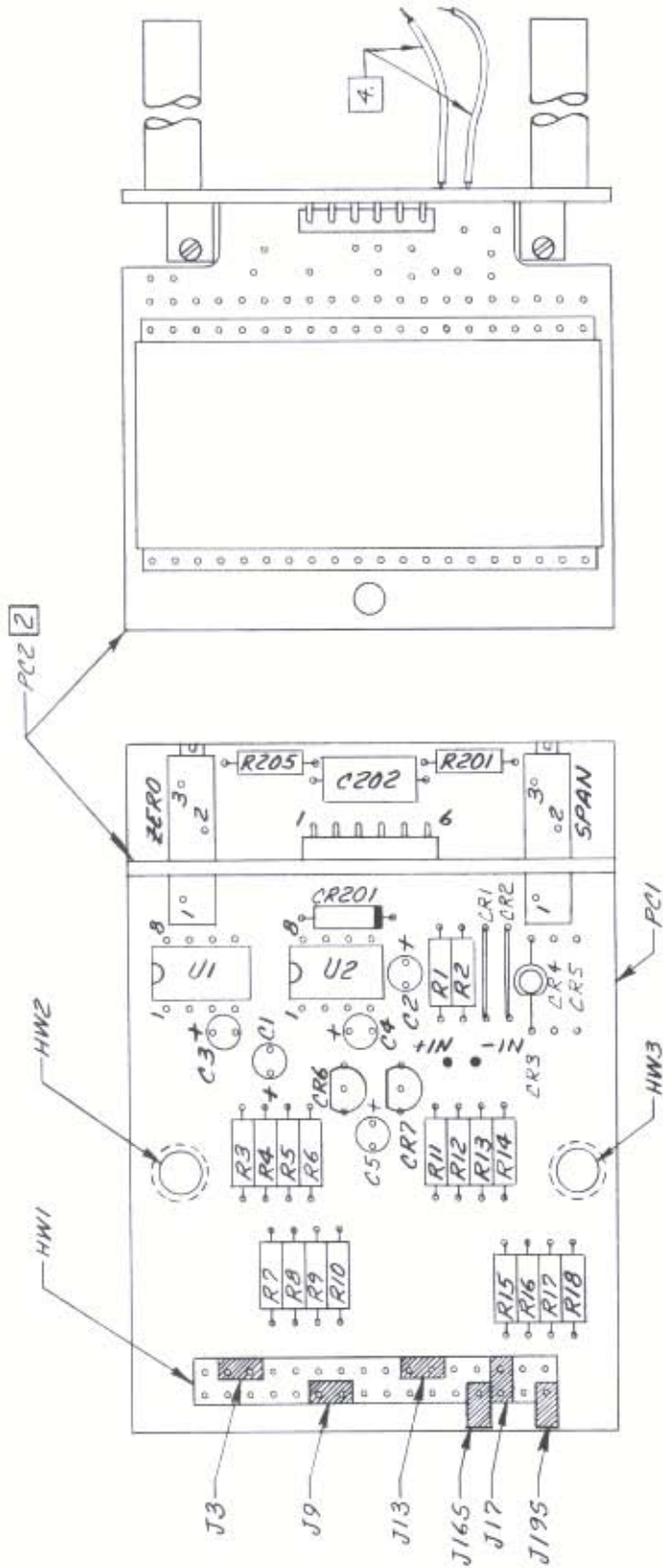

R19 MOUNTED ON SOLDER SIDE  
OF PCI WRAP LEADS OF R19 AROUND  
SPAN TRIMMER LEADS AS SHOWN.

4. SOLDER +IN AND -IN WIRES ON SOLDER (BACK) SIDE.  
3. JUMPERS PLUG ON TO HW1 IN POSITIONS SHOWN.  
2. PCI MUST SIT FLAT ON & PERPENDICULAR TO PCI.  
1. ALL LEADS TO BE SOLDERED TO PADS.
- NOTES: UNLESS OTHERWISE SPECIFIED.**

# RETURN PROCEDURES

## To return equipment to Moore Industries for repair, follow these four steps:

1. Call Moore Industries and request a Returned Material Authorization (RMA) number.

### Warranty Repair –

If you are unsure if your unit is still under warranty, we can use the unit's serial number to verify the warranty status for you over the phone. Be sure to include the RMA number on all documentation.

### Non-Warranty Repair –

If your unit is out of warranty, be prepared to give us a Purchase Order number when you call. In most cases, we will be able to quote you the repair costs at that time. The repair price you are quoted will be a "Not To Exceed" price, which means that the actual repair costs may be less than the quote. Be sure to include the RMA number on all documentation.

2. Provide us with the following documentation:
  - a) A note listing the symptoms that indicate the unit needs repair
  - b) Complete shipping information for return of the equipment after repair
  - c) The name and phone number of the person to contact if questions arise at the factory
3. Use sufficient packing material and carefully pack the equipment in a sturdy shipping container.
4. Ship the equipment to the Moore Industries location nearest you.

The returned equipment will be inspected and tested at the factory. A Moore Industries representative will contact the person designated on your documentation if more information is needed. The repaired equipment, or its replacement, will be returned to you in accordance with the shipping instructions furnished in your documentation.

### WARRANTY DISCLAIMER

THE COMPANY MAKES NO EXPRESS, IMPLIED OR STATUTORY WARRANTIES (INCLUDING ANY WARRANTY OF MERCHANTABILITY OR OF FITNESS FOR A PARTICULAR PURPOSE) WITH RESPECT TO ANY GOODS OR SERVICES SOLD BY THE COMPANY. THE COMPANY DISCLAIMS ALL WARRANTIES ARISING FROM ANY COURSE OF DEALING OR TRADE USAGE, AND ANY BUYER OF GOODS OR SERVICES FROM THE COMPANY ACKNOWLEDGES THAT THERE ARE NO WARRANTIES IMPLIED BY CUSTOM OR USAGE IN THE TRADE OF THE BUYER AND OF THE COMPANY, AND THAT ANY PRIOR DEALINGS OF THE BUYER WITH THE COMPANY DO NOT IMPLY THAT THE COMPANY WARRANTS THE GOODS OR SERVICES IN ANY WAY.

ANY BUYER OF GOODS OR SERVICES FROM THE COMPANY AGREES WITH THE COMPANY THAT THE SOLE AND EXCLUSIVE REMEDIES FOR BREACH OF ANY WARRANTY CONCERNING THE GOODS OR SERVICES SHALL BE FOR THE COMPANY, AT ITS OPTION, TO REPAIR OR REPLACE THE GOODS OR SERVICES OR REFUND THE PURCHASE PRICE. THE COMPANY SHALL IN NO EVENT BE LIABLE FOR ANY CONSEQUENTIAL OR INCIDENTAL DAMAGES EVEN IF THE COMPANY FAILS IN ANY ATTEMPT TO REMEDY DEFECTS IN THE GOODS OR SERVICES, BUT IN SUCH CASE THE BUYER SHALL BE ENTITLED TO NO MORE THAN A REFUND OF ALL MONIES PAID TO THE COMPANY BY THE BUYER FOR PURCHASE OF THE GOODS OR SERVICES.

ANY CAUSE OF ACTION FOR BREACH OF ANY WARRANTY BY THE COMPANY SHALL BE BARRED UNLESS THE COMPANY RECEIVES FROM THE BUYER A WRITTEN NOTICE OF THE ALLEGED DEFECT OR BREACH WITHIN TEN DAYS FROM THE EARLIEST DATE ON WHICH THE BUYER COULD REASONABLY HAVE DISCOVERED THE ALLEGED DEFECT OR BREACH, AND NO ACTION FOR THE BREACH OF ANY WARRANTY SHALL BE COMMENCED BY THE BUYER ANY LATER THAN TWELVE MONTHS FROM THE EARLIEST DATE ON WHICH THE BUYER COULD REASONABLY HAVE DISCOVERED THE ALLEGED DEFECT OR BREACH.

### RETURN POLICY

For a period of thirty-six (36) months from the date of shipment, and under normal conditions of use and service, Moore Industries ("The Company") will at its option replace, repair or refund the purchase price for any of its manufactured products found, upon return to the Company (transportation charges prepaid and otherwise in accordance with the return procedures established by The Company), to be defective in material or workmanship. This policy extends to the original Buyer only and not to Buyer's customers or the users of Buyer's products, unless Buyer is an engineering contractor in which case the policy shall extend to Buyer's immediate customer only. This policy shall not apply if the product has been subject to alteration, misuse, accident, neglect or improper application, installation, or operation. THE COMPANY SHALL IN NO EVENT BE LIABLE FOR ANY INCIDENTAL OR CONSEQUENTIAL DAMAGES.



**WORLDWIDE • www.miinet.com**

United States • info@miinet.com Tel: (818) 894-7111 • FAX: (818) 891-2816	Belgium • info@mooreind.be Tel: 03/448.10.18 • FAX: 03/440.17.97	China • sales@mooreind.sh.cn Tel: 86-21-62491499 • FAX: 86-21-62490635
Australia • sales@mooreind.com.au Tel: (02) 8536-7200 • FAX: (02) 9525-7296	The Netherlands • sales@mooreind.nl Tel: (0)344-617971 • FAX: (0)344-615920	United Kingdom • sales@mooreind.com Tel: 01293 514488 • FAX: 01293 536852